

TUCSON Gas-Fired Catalytic Vent-Free Room Heater (8740)

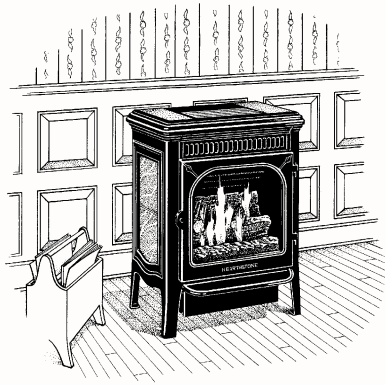

Manufactured by:
HearthStone Quality Home Heating Products, Inc.
317 Stafford Avenue
Morrisville, Vermont 05661

READ THIS OWNER'S MANUAL

Operate and maintain this gas heater according to instructions in this manual.

Read this manual in its entirety.

WARNING

If the information in this manual is not followed exactly, a fire or explosion may result, causing property damage, personal injury or loss of life.

Do not store or use gasoline or other flammable vapors and liquids in the vicinity of this or any other appliance.

Installation and service must be performed by a qualified installer, service agency or the gas supplier.

This is an unvented gas-fired heater. It uses air (oxygen) from the room in which it is installed. Provisions for adequate combustion and ventilation air must be provided. Refer to page 6 of this manual.

FOR YOUR SAFETY - WHAT TO DO IF YOU SMELL GAS

- * DO NOT ATTEMPT TO LIGHT THIS GAS HEATER OR ANY APPLIANCE
- * EXTINGUISH ANY OPEN FLAME
- * DO NOT TOUCH ANY ELECTRICAL SWITCH
- * DO NOT PLUG IN OR UNPLUG ANY APPLIANCE
- * DO NOT USE ANY PHONE IN YOUR BUILDING
- * OPEN WINDOWS IN THE ROOM AND VACATE THE BUILDING
- * TURN OFF THE MAIN GAS SUPPLY
- * IMMEDIATELY CALL YOUR GAS SUPPLIER FROM A NEIGHBOR'S PHONE
- * FOLLOW THE GAS SUPPLIERS INSTRUCTIONS
- * IF YOU CANNOT REACH YOUR GAS SUPPLIER, CALL THE FIRE DEPARTMENT

INFORMATION SHEET

Record, on this page, all relevant information concerning the purchase, installation, and maintenance of your Tucson gas-fired heater. This information will facilitate servicing, purchase of replacement parts, and warranty claims (if necessary). Keep your original receipt in a safe place as proof of purchase.

Serial Number: _____

Fuel type (check one) Natural Gas
 Liquid Propane

Sold by: _____

Phone: _____ Date of Purchase: _____

Installed by: _____

Phone: _____ Date of Installation: _____

Gas Supplier: _____

Phone: _____

Read this Owner's Manual before installing or operating the Tucson gas-fired heater. Retain this manual for future reference.

SERVICE RECORD

Date	Who Performed Work	Work Performed	Notes
_____	_____	_____	_____
_____	_____	_____	_____
_____	_____	_____	_____
_____	_____	_____	_____
_____	_____	_____	_____
_____	_____	_____	_____
_____	_____	_____	_____
_____	_____	_____	_____
_____	_____	_____	_____
_____	_____	_____	_____

WHAT	WHEN	WHAT	WHEN
Firebox Cleaning.....	annually	Door Gasket.....	replacement as needed
Catalytic combustor.....	visual check annually	Glass Cleaning.....	as needed
Catalytic combustor.....	replacement every 5 yrs. or as needed (do not clean the catalytic combustor)		

INTRODUCTION

Welcome

Congratulations on the purchase of your HearthStone Tucson Gas-Fired Catalytic Vent-Free Stove. The Tucson incorporates the latest in energy and gas technology which will provide you with clean, efficient heat for years to come. The combination of natural stone and cast iron gives the Tucson years of attractive looks and allows for durable performance which can be maintained with minimal care.

If there are any questions regarding installation or operation, which are not answered within this manual, contact your local dealer or your building inspector.

Your Tucson is equipped with a standing pilot which:

- 1) generates a millivolt signal that powers the wall-mounted thermostat and;
- 2) lights the main burner when the thermostat calls for heat. (The Tucson requires no electrical power source for normal operation).

This unit is equipped with a variable output control located on the gas control valve. It allows you to vary the heat output, along with the flame height, to suit personal needs. Heat output can be reduced during the Fall and Spring (when the need for heat is reduced) and increased during Winter months (when the need for heat is the greatest). Regardless of how you set the variable output control, the on/off cycling of the unit may be controlled by the wall-mounted thermostat, or the on/off/Tstat switch.

The Tucson will provide you with years of practical and convenient service. However, as with any gas appliance, the unit must be properly installed and maintained by qualified service personnel to ensure safe and trouble-free operation.

Before The Stove Is Lit.....13
 How To Turn The Unit On & Off.....14
 Burner Flame Appearance.....15
 Initial Adjustments.....16
 Daily Operation.....16
 Routine Maintenance and Care.....17
 Parts List.....19
 Specifications.....19
 Trouble Shooting.....20
 Warranty.....22

READ THIS OWNER'S MANUAL

Operate and maintain this gas heater according to instructions in this manual. Read this manual in its entirety.

Table of Contents

Information Sheet.....1
 Service Record.....1
 Introduction.....2
 Safety Information.....3
 Clearances To Combustibles.....5
 Hearth Requirements/Floor Protection.....5
 Fresh Air Requirements.....5
 Determining Space Classifications.....6
 Meeting Fresh Air Requirements.....9
 Packing List & Items Required For
 Installation.....9
 Unpack & Inspect For Damage.....9
 Electrical Connections.....10
 Gas Supply & Connections.....11
 Log Set Information.....12

SAFETY INFORMATION

Your Tucson Vent-Free is very attractive and extremely efficient, utilizing today's best technologies. By following a few simple safety precautions and by performing minimal maintenance, the unit will remain appealing while providing years of quality performance.

WARNING

Installation and repair should be done by a qualified service person. The appliance should be inspected before use and at least annually by a qualified service person. It is imperative that control compartments, burners, and circulating air passages of the appliance are kept clean and free of obstructions.

IMPORTANT

Please read and understand all warnings before installing or operating this heater. Failure to follow these instructions or improper use of this heater will void the warranty and can cause serious injury or death from burns, fire, explosion and carbon monoxide poisoning. Do not attempt to alter or modify the construction of this heater or its components. Any alteration or modification of construction voids the warranty and the certification of this heater. Save this manual for future reference.

DANGER: CARBON MONOXIDE POISONING MAY LEAD TO DEATH!

Carbon Monoxide Poisoning: Early signs of carbon monoxide poisoning resemble the flu with headaches, dizziness, and/or nausea. If you have these signs, get fresh air immediately! Have the heater serviced, as it may not be operating properly. As a safety precaution, a CO monitor may be installed in or near the room where the unit will be operating.

The installation must conform with local codes or, in the absence of local codes, the current National Fuel Gas Code, ANSI Z223.1 (NFPA 54).

DO NOT INSTALL THIS HEATER IN A BEDROOM OR BATHROOM.

Do not use this heater if any part has been under water. Immediately call a qualified service technician to inspect the heater and to replace any part of the control system and gas control which has been under water.

This heater has a standing pilot which incorporates an Oxygen Depletion System (ODS). The ODS shuts off the flow of gas to the pilot and the burner in the event that sufficient fresh air becomes unavailable for continued safe operation of the heater. If this heater shuts off during operation, sufficient fresh air may not be available. Refer to the Troubleshooting or Fresh Air Requirements sections

of this manual, or call a qualified service technician.

Avoid any drafts that alter the burner flame patterns. Do not allow fans to blow directly into the heater. Ceiling fans may create drafts that alter burner flame patterns. Sooting and improper burning may occur.

This unvented gas heater is intended to be smokeless. During the first few hours of operation the appliance may produce a slight smoke and/or odor. This is normal during the first burn. During the initial burn, open a window(s) to assist in the removal of the smoke/odor. If the logs appear to smoke, turn the heater off and call a qualified service technician.

During any pressure testing of supply piping system in excess of ½ psi (14" w.c.), the heater and its control valve must be disconnected from the gas supply system. If equal to or less than ½ psig, it must be isolated from the gas supply piping system by closing its individual manual shutoff valve.

SAFETY INFORMATION cont.

WARNING: DO NOT OPERATE THIS HEATER WITHOUT THE CATALYTIC COMBUSTOR PROPERLY INSTALLED. IF THE CATALYST APPEARS ALTERED OR DAMAGED, DO NOT USE THE APPLIANCE UNTIL THE CATALYST IS REPLACED.

HOT SURFACES

Certain exposed surfaces of the Tucson will reach high temperatures during normal operation. Clearances to combustibles must be maintained, as specified in the Clearances To Combustibles section of this manual. The Tucson should be located out of traffic and away from furniture, draperies, clothing and flammable materials. Do not place objects that may obstruct air circulation on, under, or near the heater. Do not place objects on the top grill of the stove. Doing so will obstruct the air flow of the stove, preventing it from operating properly. Clean the area around, under, and behind the unit on a regular basis to prevent the accumulation of dust and lint.

Children and adults who are unfamiliar with heaters of this type should be alerted to the hazards of high surface temperatures and warned that they should stay away to avoid burns to skin and clothing. Children should be carefully supervised when in the same area as the Tucson heater. Do not leave children unattended in the vicinity of this unit.

NEVER BURN PAPER, WOOD, OR OTHER MATERIALS

This gas heater is designed to burn either natural gas(NG) or liquid propane(LP). Never burn any fuel which was not intended for use.

DO NOT LIGHT PILOT OR MAIN BURNERS BY HAND

The standing pilot light equipped with this gas heater is lit by using a piezoelectric spark generator, as described in the How To Turn the Unit On & Off section of this manual. Never attempt to light the pilot or main burners by hand (with a match or lighter). After repeated attempts, if the pilot light fails to light, discontinue operation, turn off the gas at the gas control valve, and immediately contact qualified service personnel for assistance.

FIRE HAZARD

Do not store or use gasoline or other flammable vapors and liquids in the vicinity of this appliance. The Tucson should be

located out of traffic and away from furniture, draperies, clothing, and flammable material.

CERAMIC FIBER LOG SAFETY INFORMATION

If the decorative ceramic logs and ember strip material supplied with the Tucson are damaged or missing, they must be replaced with the same, approved replacement parts supplied by the manufacturer. These components affect the combustion quality and safety of the heater. Do not replace fiber ceramic logs or ember strip with unapproved ceramic logs or any other material. **Always wear gloves and safety goggles while handling the log set and ember strip.**

SERVICE CAUTION

If you believe your Tucson is not, in any way, performing properly, immediately discontinue operation until the unit has been inspected and approved by qualified service personnel. Prior to servicing the unit, turn the valve control knob clockwise to "OFF". The unit should be cool prior to servicing and cleaning. Any component removed during servicing should be replaced prior to operation. Use of any components not supplied by HearthStone. on the stove voids all warranties. **Do not substitute components.**

CLEARANCES TO COMBUSTIBLES

Due to high surface temperatures, the Tucson should be located out of traffic and away from furniture and draperies. Clothing and other flammable material should not be placed on or near the Tucson heater. Always maintain adequate clearances around the air openings into the combustion chamber and allow for adequate ventilation. Minimum clearances to combustibles must be maintained as shown to the right, in Figures 1-4.

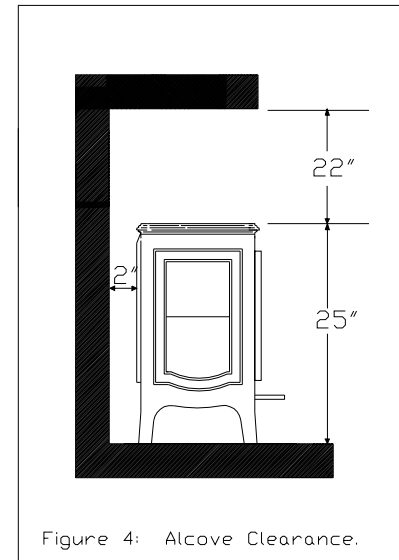
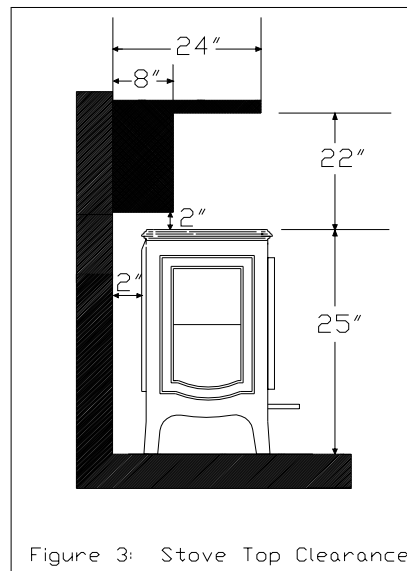
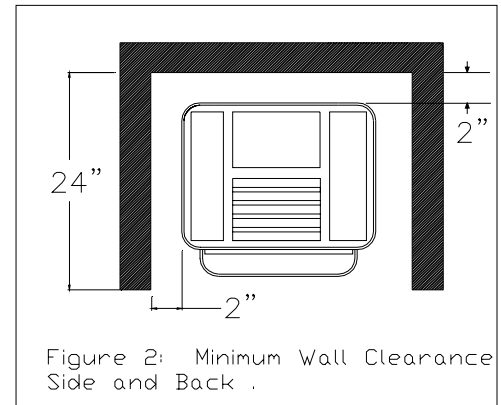
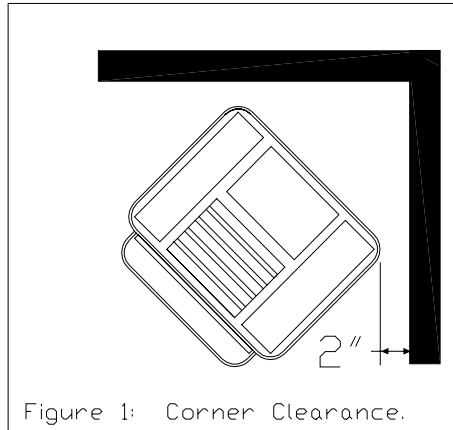

HEARTH REQUIREMENTS/FLOOR PROTECTION

The Tucson can be installed on wood flooring or a non-combustible surface. For installation of the Tucson on carpeting, vinyl tile, or other combustible materials other than wood flooring, the unit shall be installed on a metal, wood, or other non-combustible hearth.

The required size of the hearth is the same as the outline of the stove (shown in Figure 19).

NOTE: Some wood floor varnishes, stains, or polyurethane may be affected by heat.

CODES

Adhere to all local codes or, in their absence, the latest edition of THE NATIONAL FUEL GAS CODE ANSI Z223.1 (NFPA54) which can be obtained from:

AMERICAN NATIONAL STANDARDS INSTITUTE, INC.

1430 BROADWAY
NEW YORK, NY 10018

OR

NATIONAL FIRE PROTECTION ASSOCIATION, INC.

BATTERY MARCH PARK
QUINCY, MA 02269

FRESH AIR REQUIREMENTS

Your Tucson stove requires an adequate supply of fresh air to function properly and safely. The fresh air supply must be met within the space in which the heater is to be installed. To ensure an adequate supply of fresh air is available for proper and safe operation of your Tucson stove, the following

information must be considered when installing the appliance in a mobile home, modular home, or an on-site house. Refer to Figure 5.

The space in which the heater should be installed will fall

into one of the following categories:

1. Unusually tight construction
2. Unconfined space
3. Confined space

WARNING: If the area in which the heater may be operated is smaller than that defined as an unconfined space, provide adequate combustion and ventilation air by one of the methods described in the National Fuel Gas Code ANSI Z223.1, Latest Edition, Section 5.3.

DETERMINING SPACE CLASSIFICATION

Unusually tight construction

This is construction where:

- a. Walls and ceilings exposed to the outside atmosphere have a continuous water vapor retarder with a rating of one perm (6×10^{-10} kg per pa-sec- m^2) or less with openings gasketed or sealed, and
- b. Weatherstripping has been added on openable windows and doors, and
- c. Caulking or sealants are applied to areas such as joints around window and door frames, between sole plates and floors, between wall ceiling joints, between wall panels, at penetrations for plumbing, electrical, and gas lines, and at other openings.

If the space in which the heater will be installed falls into this category, supplemental fresh air must be provided, as outlined in the Meeting Fresh Air Requirements section of this manual.

Unconfined space

If the space in which the heater is to be installed meets the following criteria, it is considered to be an unconfined space.

The room in which the heater is to be installed has an air volume of at least 50 cubic feet (cubic feet = length x width x height of the space) for each 1000 BTU/hr (4.8 m^3 / K. W.) input rating for all appliances in the space. This includes adjoining rooms only if there are doorless passageways between them, or there are vents between the rooms. If the space in which the unit is being installed is an unconfined space, additional fresh air is not needed.

Confined space

If the space in which the heater is to be installed meets the following criteria, it is considered a confined space.

The room in which the heater is to be installed has an air volume of less than 50 cubic feet for each 1000 BTU/hr (4.8 m^3 / K. W.) input rating for all appliances in the space. This includes adjoining rooms only if there are doorless passageways between them, or there are vents between the rooms. (See Figure 5).

If the space in which the heater is to be installed is a confined space, additional fresh air must be provided. This can be done by one of the ways outlined in the Meeting Fresh Air Requirements section of this manual.

Example (refer to Figure 5)

- I. Determine the volume of the space where the unit will be installed. Volume = length x width x height. Also included in the volume of the space is the volume of any adjoining rooms, only if there are doorless passage ways between them, or if there are vents between the rooms.
- II. Multiply the volume by 1000 BTU/hr, then divide that number by 50 cubic feet, to obtain the

DETERMINING SPACE CLASSIFICATION cont.

total maximum BTU/hr rating which the room can support.

III. Add the BTU/hr ratings of all fuel burning appliances installed within the same space. The BTU rating for this unit is 20,000 BTU/hr. (Do not include any direct vent appliances, as these types of appliances use outside air for combustion and venting).

IV. Compare the maximum BTU/hr rating that the room can support (from II.) with the maximum BTU/hr rating of the combined appliances (from III.). If the number from III. is smaller than the number calculated in II., the space should be considered an unconfined space. If the number from III. is larger than II., the space should be considered a confined space, and additional fresh air must be provided. This can be done by one of several ways.

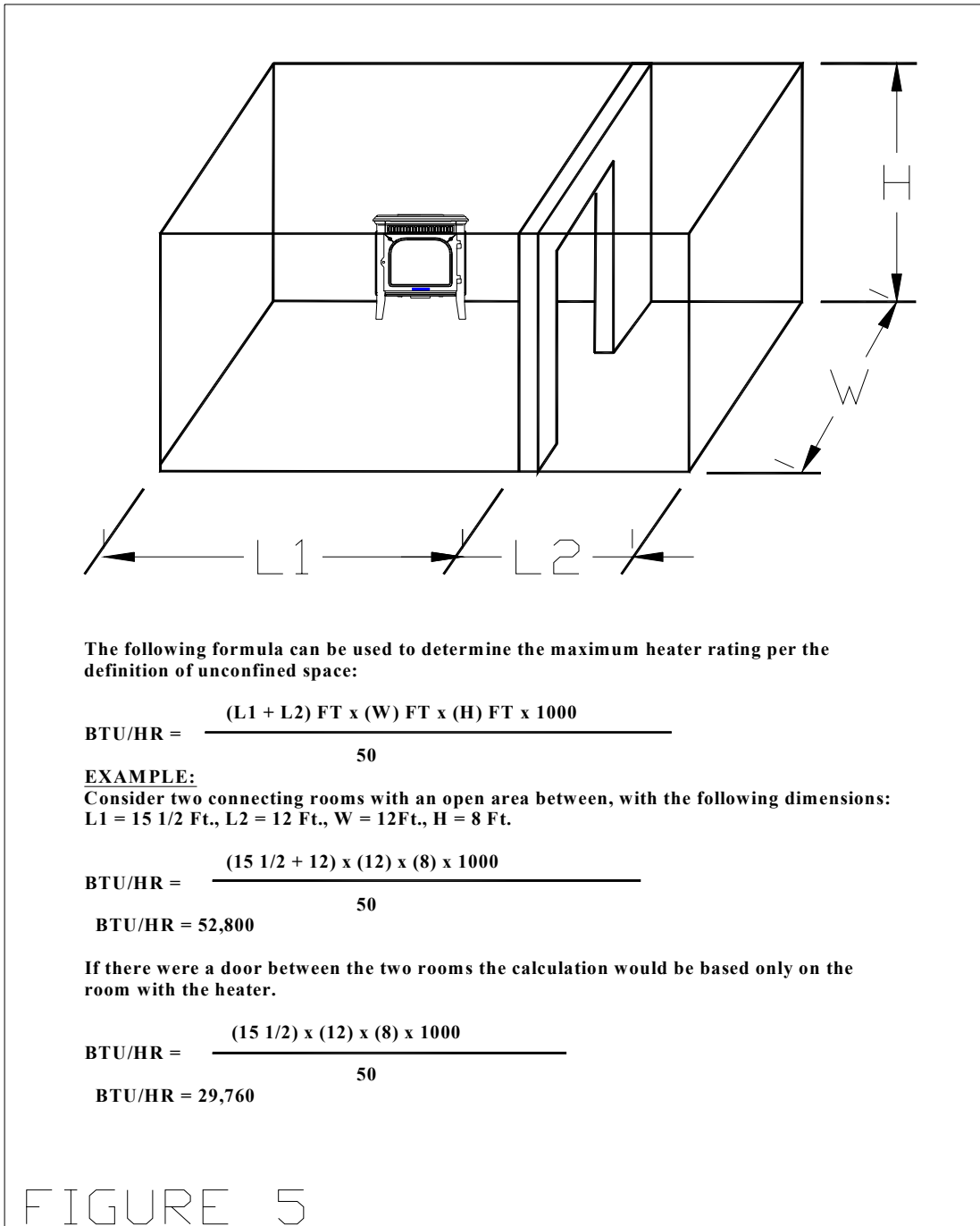

MEETING FRESH AIR REQUIREMENTS

1. *Air from inside the building.* The confined space shall be provided with two permanent openings communicating directly with an additional room(s), of sufficient volume, so that the combined volume of all spaces meets the criteria for an unconfined space. The total input of all gas utilization equipment installed in the combined space shall be considered in making this determination. Each opening shall have a minimum free area of 1 square inch per 1,000 BTU/hr (22 cm² / kW) of the total input rating of all gas utilization equipment in the confined space, but not less than 100 square inches (645 cm²). One opening shall commence within 12 inches (30 cm) of the top, and one opening shall commence within 12 inches (30 cm) of the bottom, of the enclosure. The minimum dimension of air openings shall not be less than 9 square inches (8 cm) (see Figure 6).

2. *All air from outdoors.* The confined space needs to have two permanent openings, one commencing within 12 inches (30 cm) of the top, and one commencing within 12 inches (30 cm) of the bottom, of the enclosure. The openings shall communicate freely with the outdoors, either directly, by ducts, or by spaces (crawl or attic). The minimum dimension of air openings shall be not less than 9 square inches (8 cm). See Figures 7 thru 9.

A. Where directly communicating with the outdoors, each opening shall have a minimum free area of 1 square inch per 4,000 BTU/hr (5.5 cm² / kW) of total input rating of all equipment in the enclosure. See Figure 7.

B. Where communicating with the outdoors through vertical ducts, each opening shall have a minimum free area of 1 square inch per 4,000 BTU/hr (5.5 cm² / kW) of total input rating of all equipment in the enclosure (See Figure 8).

C. Where communicating with the outdoors through horizontal ducts, each opening shall have a minimum free area of 1 square inch per 2,000 BTU/hr (11 cm² / kW) of total input rating of all equipment in the enclosure (See Figure 9).

D. Where ducts are used, they shall be of the same cross-sectional area as the free area of the openings to which they connect.

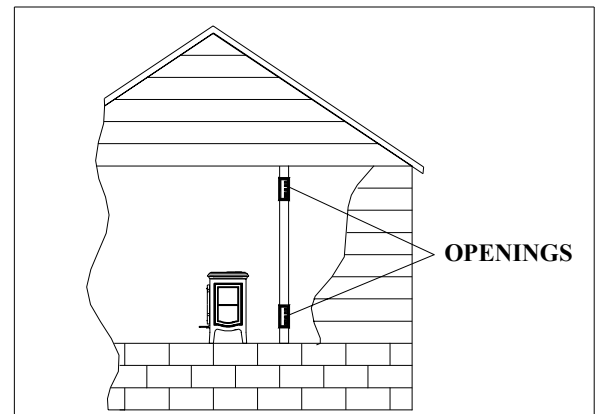

FIGURE 6

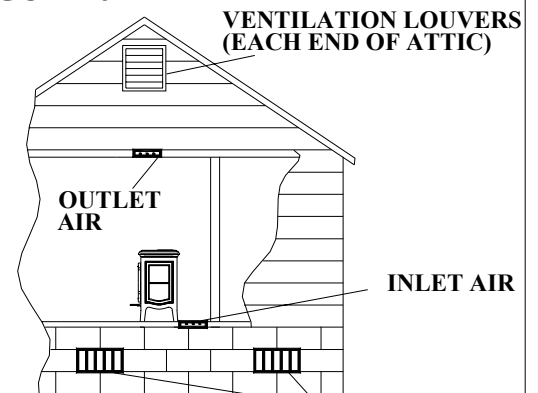

FIGURE 7 VENTILATION LOUVERS FOR UNHEATED CRAWL SPACE

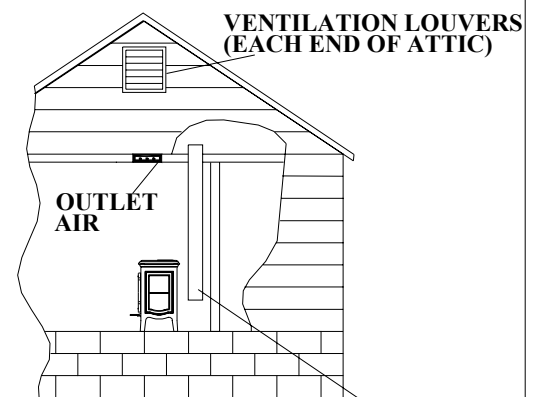

FIGURE 8 INLET AIR DUCT (ENDS 1 FT ABOVE FLOOR)

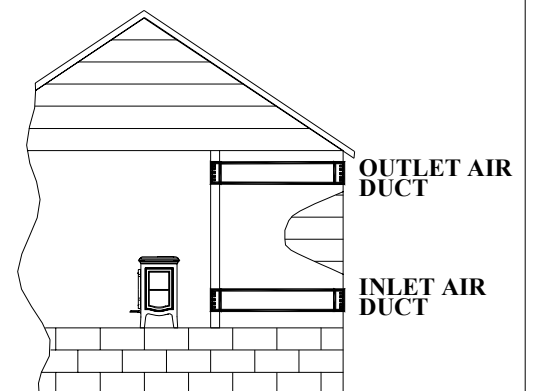

FIGURE 9

PACKING LIST & ITEMS REQUIRED FOR INSTALLATION

Packing list

- 1 - Tucson Vent-Free Gas-Fired Heater
- 1 - Decorative Ceramic Fiber Log
- 1 - Ember Strip
- 1 - Thermostat with 40' wire
- 1 - Owners Manual
- 1 - Warranty Validation Form

Items Required For Installation

Ensure that the following items are available before proceeding with installation:

- 1/8 Allen wrench
- An external regulator (for propane/ L. P. gas only)
- Gas piping which complies with local codes
- Pipe sealants approved for use with propane/L. P. Gas (resistant to sulfur compounds)
- A manual shutoff valve for the gas supply
- A sediment trap
- Pipe wrenches
- Phillips head screwdriver
- Other parts required by local code
- Safety glasses
- Gloves

UNPACK & INSPECT FOR DAMAGE

Unpack

The Tucson is packaged by the manufacturer to withstand shipment without damage under most circumstances. However, damage can occur during transit and handling. Care should be taken when unpacking, inspecting for damage, and installing the unit. **If any damaged or missing parts are detected, immediately contact your dealer.**

After removing the shipping carton, carefully remove the top three stones and grill. Use the protective wrapping material to temporarily protect the stones from chipping or damage while the unit is inspected and installed.

With the top stones and grill removed and set aside, undo the lag bolts that fasten the unit to the pallet. Take care not to mar or chip the legs if enameled. Lift the stove off the pallet and set it in place, (with regards to the Clearances To Combustibles section of this manual.)

Inspect for damage

Inspect the Tucson for visible and/or concealed damage. The unit should appear to be square and true. The stones should be whole and without cracks, chips, or breakage. The sheet metal parts should be smooth and free of bends and/or dents.

If the heater is enameled, the enameled cast iron should be free of chips and/or cracks. If visible or concealed damage is found or suspected, contact your local dealer for instructions.

The Owner's Manual, thermostat (with wire), removable

ash lip, and the decorative ceramic fiber logs, supplied with the Tucson, are contained within the firebox. It is important to wear the safety goggles and gloves when handling the log set. Open the firebox door using a 1/8 allen wrench and inspect the logs for damage. If a damaged log is encountered, contact your local dealer for replacement logs. Put the logset, thermostat, and the ash lip aside. They will be installed later.

ELECTRICAL CONNECTIONS

NOTE: OPEN VALVE DOOR UNDER ASH LIP FOR ELECTRICAL AND GAS CONNECTIONS

Thermostat

The Tucson may use the wall mounted thermostat for operation, or the on/off/tstat switch. The thermostat controls the unit by “calling for heat.” The thermostat turns the unit on when the room is cold, and turns the unit off once the room is warmed sufficiently. The thermostat is controlled by a 750 millivolt DC two-wire circuit. Both the thermostat and 40' (12m) of thermostat wire are included as standard equipment.

Thermostat Placement

The thermostat should be placed in the same room or living space as the unit. Typically 5' (1.5 m) off the floor and away from any influences that may cause the temperature in the vicinity of the thermostat to be unrepresentative of the room temperature in general. Such influences might include strong lighting, a heater vent from the central heating system, or a nearby drafty window.

Placement of the thermostat on an inside wall rather than an outside wall is preferable. Do not place the thermostat directly behind or too close to the unit, otherwise heat from the unit will immediately satisfy the thermostat and turn the unit off.

Thermostat Wiring

The thermostat wire from the unit to the thermostat can be surface mounted, routed under the floor, or through walls, etc. The thermostat should be connected to the unit using the 40' (12 m), or as much as needed, of insulated thermostat wire provided. Be sure to leave a small coil of wire behind the unit so that it can be moved out of position for servicing and cleaning.

The proper location of wire connections is shown below and in Figure 10. When making these connections, position the thermostat wire so it extends towards the wall behind the unit, then towards the thermostat. (At the thermostat, the wires should be connected to the two connection screws on the back of the thermostat per the instructions received with the thermostat). Take care not to over-tighten the connection screws and not to damage the internal parts of the thermostat. Now attach the wires in their proper location, shown in Figure 10.

Location of Wire Connections:

WIRE	LOCATION	LABEL
Thermostat(2 wires)	1- Top Post on Valve	TH
	1- On/Off/T-stat switch	Yellow wire
Thermopile(2 wires)	1- Bottom Post	TP/TH
	1- Middle Post	TP

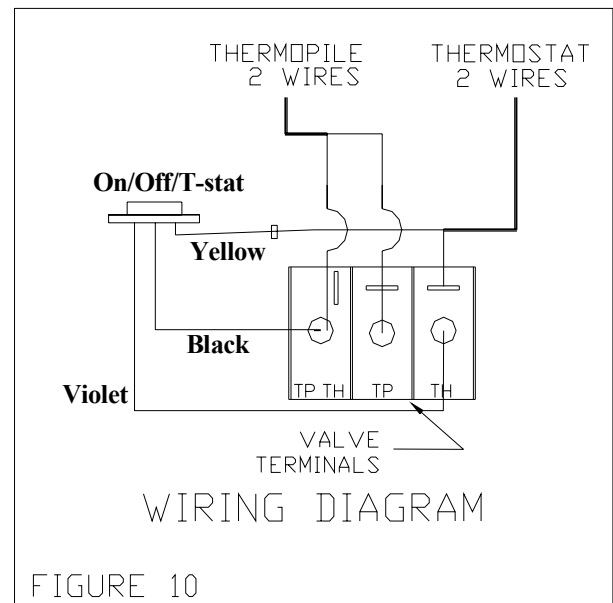

GAS SUPPLY & CONNECTIONS

Gas Supply

NOTICE: A qualified technician must connect the heater to the gas supply and leak test the unit before it is approved for use. Consult all local codes.

WARNING: The unit must be installed and connected in accordance with local codes, or in the absence of local codes, with the most current edition of the National Fuel Gas Code ANSI Z223.1/NFPA 54.

We recommend using new black iron or steel pipe only. Internally tinned copper tubing can be used in some areas when permitted by local codes. Only use pipe of 1/2" or greater diameter to allow full gas volume to heater. Excessive pressure loss will occur if the pipe is too small.

The supply line must include a manual shut-off valve and union so that the unit can be disconnected for servicing. Also a sediment trap must be installed upstream of the heater. The sediment trap is installed to prevent moisture and contaminants from passing through the pipe to the heater controls and burners. Failure to install a sediment trap could prevent the heater from operating reliably.

The gas supply line connection is made to the Tucson's gas control valve just inside the left front leg of the unit using a 3/8" male NPT fitting. The supply line should be 1/2" diameter or appropriately sized to provide a sufficient gas supply to meet the maximum demand of the unit without undue loss of pressure. We

recommend a flexible line to avoid undue mechanical load on the valve and to ease thread alignment, but also refer to local code.

CAUTION: Check Gas Type! The gas supply must be the same as stated on the heater's rating plate (located on the back of the unit). If the gas supply is different, **DO NOT INSTALL** the heater. Contact your dealer for the correct model.

Gas Pressure Adjustment

The supply line pressure is tested, to ensure it meets the minimum pressure, as listed in the Specifications sections of this manual, for the type of fuel in use (NG or LP). The Tucson must be isolated from the gas supply piping system by closing its individual manual shutoff valve during any pressure testing of the gas supply piping system at test pressures equal to or less than 1/2" psig. During tests in excess of 1/2" psig. (14" w.c.), the heater must be disconnected from the gas supply system. Test by connecting a manometer to the supply line. Adjust the incoming pressure, if necessary, to meet the required supply line pressure. Once connected to the gas supply, the gas inlet pressure and manifold gas pressure must be tested. The gas inlet tap (6) and manifold pressure tap (7) is located on the control valve (see Figure 11). Connect a manometer to the test points on the gas control valve, refer to #'s 6 & 7 of Figure 11 for locations.

VALVE DESCRIPTION

- | | | |
|--|------------------------------|-----------------------------------|
| ① Gas cock knob | ⑥ Inlet pressure test point | ⑪ Flange securing screw holes |
| ② Manual HI-LO adjustment or pressure regulator adjustment | ⑦ Outlet pressure test point | ⑫ Additional valve mounting hole |
| ③ Pilot adjustment | ⑧ Main operator | ⑬ Alternative TC connection point |
| ④ Thermocouple connection | ⑨ Pilot outlet | ⑭ Thermoelectric unit |
| ⑤ Mounting for piezo & bracket | ⑩ Main gas outlet | |

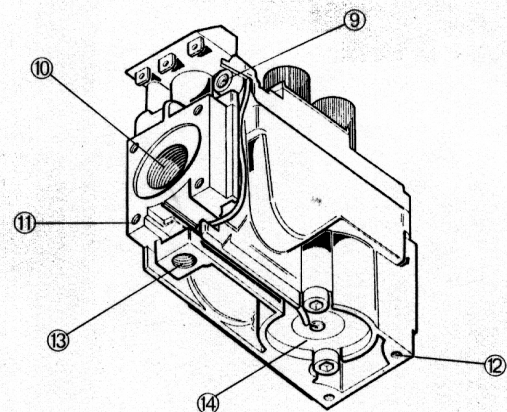
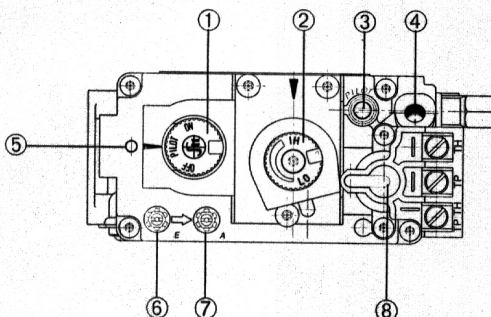

Figure 11

LOG SET INFORMATION

CAUTION: Fragile! Handle log set and ember strip with care. Always wear gloves and safety goggles while handling the log set and the ember strip.

Log Placement Within The Unit

Only the decorative ceramic fiber log set supplied with the unit should be placed in the firebox. Do not place other ceramic logs, real wood logs or other material in the firebox. If the log set is damaged or broken contact your dealer for replacement.

If the log set does not set into the firebox exactly as outlined below, contact your dealer for assistance. Exact positioning of the log set is required in order to obtain a pleasing flame pattern and efficient combustion. Incorrect log placement may cause carbon build-up, excess thermal stress on the log set and stove parts, reduced efficiency, and high levels of carbon monoxide.

The decorative ceramic fiber log set will give long service when in use; however, they will break if subjected to rough or improper handling. Broken or cracked logs should be replaced. When removing and replacing the log set from the unit during routine cleaning or service of the unit, take care not to damage the logs and to position the log set per instructions above. Also, take care not to chip the enamel on the door and door frame when removing and replacing the log set.

Installation of Log Set

Refer to figures 12 & 13 for log set assembly

1) Open the front door using a 1/8" allen wrench. Loosen the bolt that fastens the door frame to the firebox by turning it counterclockwise. Be careful not to chip enamel when loosening the bolt. Pull the door open by grabbing the top edge of the door frame.

2) Remove the packaging material around the log set assembly. Be careful not to damage the log set when unpacking.

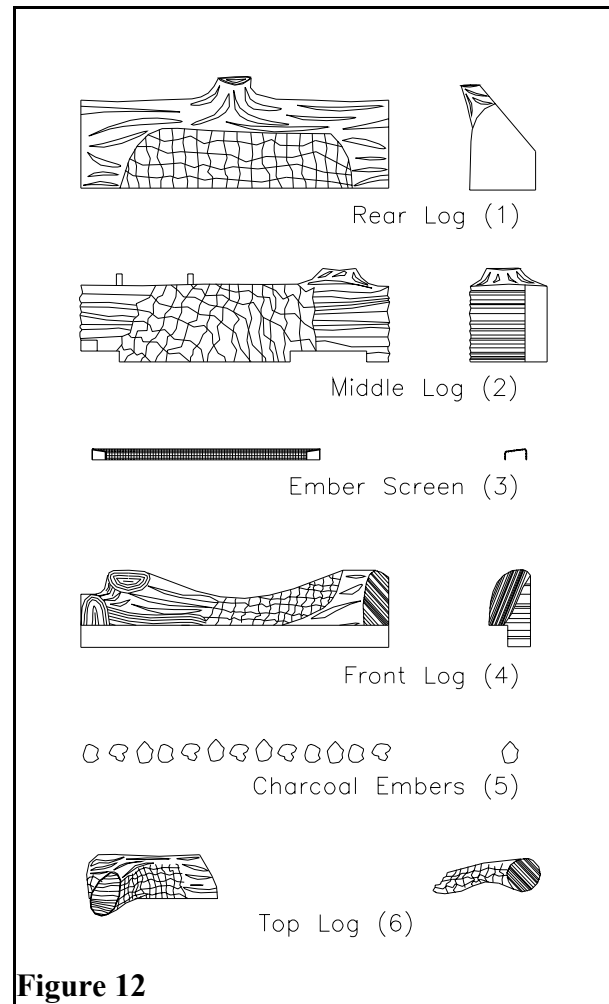

Figure 12

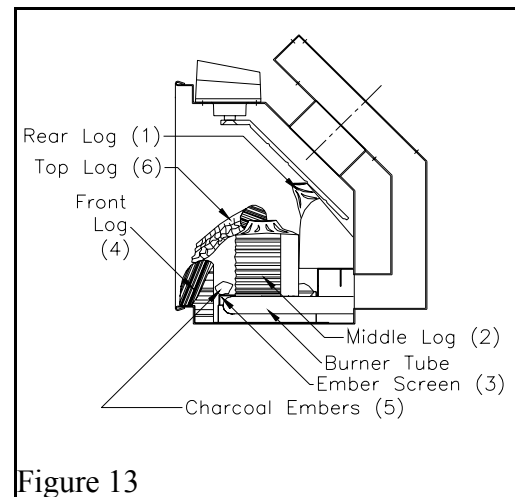

Figure 13

LOG SET INFORMATION cont.

- 3) Gently place the Rear Log (1) in the firebox against the center of the back wall.
- 4) Gently place the Middle Log (2) in the fire box against the front of the Rear Log. There are slots on the underside that fit in between the burner tube and into the burner tube holder. The rear tabs on the Middle Log should touch the front of the Rear Log, and the log should be centered as best as possible.
- 5) Place the Ember Screen (3) on the front burner tube with the long side of the Screen to the front, and the tabs should be facing down.
- 6) Gently place the Front Log (4) in the firebox against the front of the burner tube. Center as best as possible.
- 7) Spread evenly across the Ember Screen, the 2 ounces of Charcoal Embers (5).
- 8) Gently place the Top Log (6) in the firebox on top of the Middle Log. The Middle log has 2 posts which slide into the 2 holes on the underside of the Top Log. The "leg" on the Top Log points towards the front.
- 9) With the 1/8" allen wrench fasten the door to the firebox. Make sure the door is properly secured to the firebox before turning the unit on. Be careful not to chip the enamel when fastening the door.

Removal of Log Set

CAUTION: Log set and charcoal embers retain heat and can be very hot! Allow 2 to 3 hours after pilot light is turned off before handling.

CAUTION: Fragile! Handle log set and charcoal embers with care.

Open door using the 1/8 allen wrench. Loosen the screw that secures the door to the firebox by turning it counterclockwise. Pull the door open by grabbing the top edge of door frame. Take care not to chip the enamel or to damage the log set when removing the log set from the firebox. The log set assembly will be in four pieces along with the charcoal embers as shown in *Figure 13*. First, remove the Top Log(6) by pulling it up off the Middle Log(2) and out of the firebox. Next remove the charcoal embers. Then lift upwards and pull the Front Log(4) out of the firebox. Next remove the ember screen(3) from the burner tube. Grip the Middle Log(2) and lift upward, off the burner tube holder, and out of the firebox. The Rear Log(1) can then be removed from the firebox. Place the logs and charcoal embers in a safe area where they will not be damaged.

BEFORE THE STOVE IS LIT

CAUTION: Lighting the Tucson for the first time and adjustments to the unit should be performed by qualified service personnel.

WARNING: If you do not follow these instructions exactly, a fire or explosion may result causing property damage, personal injury or loss of life.

When lit for the first time, the unit will emit some smoke and fumes. This is normal "off-gassing" of the paints and oils used in the manufacturing and assembly of the unit. Open windows to vent the room if necessary. The off-gassing and fumes will subside after the first 10 to 20 minutes of operation.

Initial Adjustments

Once the Tucson has been set in place and connected as described in the Gas Supply & Connections and Electrical Connections sections of this manual, the unit is ready to be lit for the first time. Each unit is tested prior to shipment by the manufacturer, so ignition should take place without failure. However, a number of small adjustments may be necessary to compensate for variations in gas pressure, altitude, and other factors particular to each installation.

Smoke and Fumes Warning

BEFORE THE STOVE IS LIT cont.

Odors and Impurities

A Vent-Free combustion system is such that odors may be produced during heater operation due to impurities that may exist in the immediate area. Sources of impurities can be cleaning solvents, paint solvents, cigarettes, smoke, pet hair, dust, adhesives, new carpet, and/or textiles. If any fumes of this sort mix with the combustion fumes, an odor may develop. Such odors will dissipate. However, the condition can be alleviated by opening a window or otherwise providing additional ventilation to the area. If any odor persists, contact your dealer or an authorized service technician.

WARNING: THE CONTROL HAS AN INTERLOCK DEVICE. AFTER SHUTTING OFF ALL GAS FLOW, THE PILOT BURNER CANNOT BE RELIT UNTIL THE THERMOCOUPLE HAS COOLED, ALLOWING THE ELECTROMAGNET TO BE RELEASED (APPROX. 60 SEC). THE GAS CONTROL KNOB IS DESIGNED TO BE OPERATED BY HAND. NEVER USE ANY TOOLS DURING THIS OPERATION. IF THE KNOB WILL NOT PUSH IN OR TURN BY HAND, DON'T TRY TO REPAIR IT, CALL A QUALIFIED SERVICE TECHNICIAN. DAMAGED KNOBS MAY RESULT IN FIRE, EXPLOSION, OR SERIOUS INJURY.

Pilot Light Warning

The Tucson has a piezoelectric spark ignitor (the push button located next to the gas control valve behind the valve access door) which ignites the pilot light by means of a spark at the pilot light assembly. Do not attempt to light the unit with a match or by any means other than the piezoelectric spark ignitor.

Prepare for Lighting

Prepare for the lighting procedure by adjusting the thermostat to its lowest setting or OFF position. If the gas control knob is not in the OFF position, turn the knob fully clockwise to OFF. Locate the variable output and turn it fully clockwise to the highest setting.

Prior to lighting the unit for the first time, wait 5 minutes to allow any residual gas within the unit to dissipate. Smell all around the appliance area for gas. Be sure to smell next to the floor because some gases are heavier than air and will settle on the floor. If you do not smell gas after this five minute period, proceed with the lighting procedure. If you do smell gas, do *not* proceed with the lighting procedure. Instead, **immediately refer to the What To Do If You Smell Gas Warning, on the cover of this manual.**

HOW TO TURN THE UNIT ON & OFF

Lighting the Unit

1. STOP! Read the What To Do If You Smell Gas! warning.
2. Set the on/off/T-stat switch or thermostat to the off position.
3. Push in and turn the gas control knob clockwise to "OFF".
4. Wait (5) five minutes to clear out any gas. If you then smell gas, STOP!, ***immediately follow the What To Do If You Smell Gas! warning*** (on the cover of this manual). Smell all around the appliance area for gas. Be sure to smell next to the floor because some gases are heavier than air and will settle on the floor. If you do not smell gas, proceed to the next step.
5. Turn the gas control knob counterclockwise to "PILOT".
6. Push in the control knob all the way and hold it in. Immediately light the pilot with the gas lighter (push in and "click" the piezoelectric spark ignitor button several times until lit). Continue to

hold the control knob in for about 20 seconds after the pilot is lit. Release the knob and it will pop back out. The pilot should remain lit. If the pilot goes out, repeat the operation.

HOW TO TURN THE UNIT ON & OFF cont.

- * If the knob does not pop out when released, stop and immediately call a qualified service technician or gas supplier.
- * If the pilot will not stay lit after several tries, turn the gas control knob clockwise to "OFF" and call a qualified service technician or gas supplier.
- 7. After the pilot lights, turn the gas control knob counterclockwise to "ON".
- 8. Select the "ON" or "T-STAT" position of the On/Off/T-stat switch. Shut the gas control valve access door.
- 9. If the "T-STAT" position was selected, set thermostat to "ON" and set the desired temperature setting.

NOTE: When pressing/clicking the piezoelectric spark ignition button to light the pilot, watch through the glass (front door) of the unit. Click the ignitor button until a flame is visible at the pilot. Once the pilot is lit, continue to press on the gas control knob for another 20 seconds, then release. Ascertain that the pilot is still lit by looking through the front door. If lit, then turn the gas control knob fully counterclockwise to the "ON" position. If the pilot fails to light or if it went out due to a premature release of the gas

control knob while pressed in the "PILOT" position, wait 60 seconds for the Interlock to release. Then repeat the lighting process as described in the Lighting the Unit portion of this section of the manual.

Once the pilot has been lit, and the gas control knob has been turned to the "ON" position, the main burners are lit by selecting "ON" of the On/Off/T-stat switch, or if "T-STAT" was selected, by moving the thermostat to a high setting so that it "calls" for heat (i.e. turns the unit on). The main burners should light immediately. Note that the on/off cycling of the main burners is controlled by the thermostat, but the pilot remains lit regardless of the thermostat setting. To turn the pilot off, turn the gas control valve fully clockwise to the "Off" position.

Turning Off the Unit

1. Set thermostat to the "Off" position.
2. If shutting the unit off for the non-heating season, turn the gas control knob fully clockwise to the "Off" position. Do not force the knob to turn.

BURNER FLAME APPEARANCE

Burner Flame Appearance

Once the unit is lit, observe the flame pattern and adjust as necessary. Also a periodic visual check of the burner flame should be performed. To determine if the burner flame needs adjustment, it is necessary to view the flame pattern with the variable output control knob at its highest setting (turned fully clockwise). Allow the unit to operate for 10 minutes enabling the entire unit to reach temperature and for the flame pattern to stabilize. The flame pattern should be similar to the one shown in Figure 14. There are several guidelines to aid in determining if the flame pattern is correct:

- 1) the flame should not be dirty or lick the top of the stove
- 2) the flame should not raise off of the burner tube, called "lifting"
- 3) flames should not impinge heavily on log set, they should "fit" through the pre-formed spaces designed in the log set

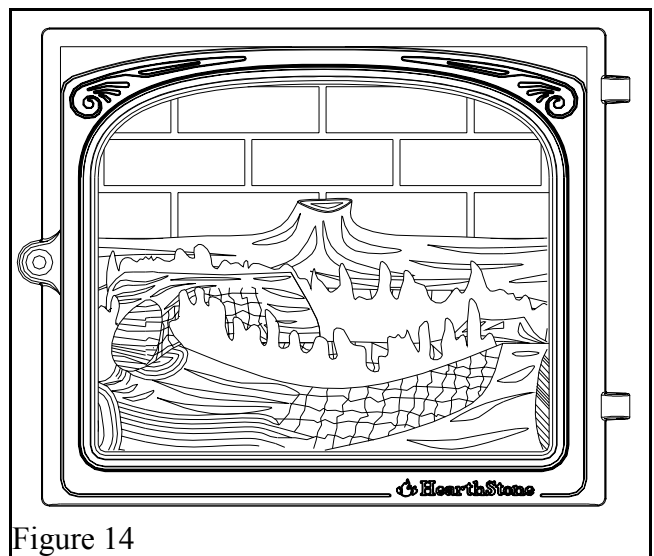

Figure 14

INITIAL ADJUSTMENTS

Variable Output Control

The gas control valve is equipped with a variable output control. This control varies the *rate* of heat produced by the unit by varying the gas pressure to the main burner tube. The *length* of the burn cycle is affected by a combination of heat output and the thermostat setting. If your stove cycles on and off often, try, first, reducing the burn cycle by turning the *HI/LOW* knob, on the control valve to a lower setting.

Using the variable output control, the heat output of the unit can be reduced for mild fall and spring months, or maximized for the colder winter months. This adjustment can be made by the homeowner as necessary by turning the variable output control knob to "*HI*", "*LO*", or any setting in between.

Air Shutter

The air shutter is preset by the manufacturer for optimum operation and should not be adjusted by the owner. The air shutter is used to regulate the air-to-gas combustion mixture which in turn influences the size and color of the flames.

Pilot Adjustment

The pilot light is preset by the manufacturer and should not need adjustment. The pilot light flame should be large enough to engulf the thermopile and, on a NG assembly, the thermocouple as well (located next to the pilot), but not so large as to create excessive noise or consume excessive gas. However, it can be adjusted by means of the pilot light adjustment screw located on the gas control valve. Open valve door to access the pilot adjustment screw. Refer to # 3 of *Figure 11* to

determine the location of the pilot adjustment screw.

Note that the pilot flame must engulf the thermopile so that the thermopile can generate sufficient millivoltage (325 to 750mv) to power the millivolt gas control valve. The flame on the pilot should look like *Figures 15a & 15b*. Controlling the Tucson by the wall mounted thermostat may become erratic, nonexistent, or the unit may go out, if the pilot light flame is too small or misdirected away from the thermopile.

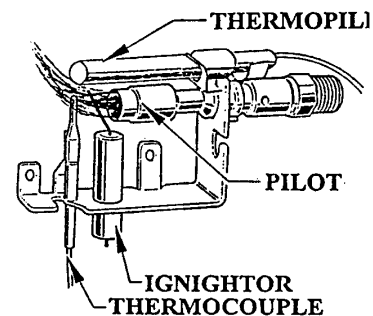

Figure 15a Pilot Flame Pattern (NG GAS)

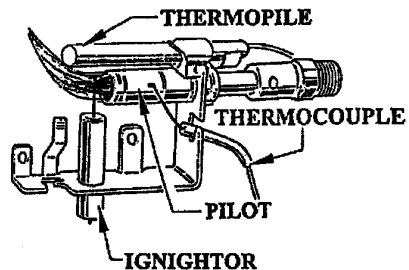

Figure 15b Pilot Flame Pattern (LP GAS)

DAILY OPERATION

Daily Operation

The Tucson gas-fired heater is easily operated by the homeowner once installed and adjusted by qualified service personnel. The unit is controlled via the wall-mounted thermostat during the heating season. Set the thermostat to the desired room temperature and the unit will cycle on and off as required. By adjusting the variable output control,

located on the gas control valve, the rate of heat output can be varied to meet the heating requirements of the season. Choosing a low flame setting will result in longer burn cycles at a reduced output, while choosing a high flame setting will result in a shorter, hotter burn cycle.

DAILY OPERATION cont.

Through trial and error the homeowner can select the optimum flame size for their setting and application.

During the summer, non-heating season, switch the wall thermostat to "OFF", and turn off the pilot. This will improve the overall efficiency of the unit as the heat from the pilot is not wanted in the summer. When putting the unit back into service follow the Lighting

the Unit portion in the How To Turn the Unit On & Off section of this manual.

When the unit is first lit, especially when cool, it is normal to experience some condensation on the inside of the glass window. This condensation will burn off within the first few minutes of operation. If continuous condensation or water drips are noted from any part of the unit, immediately discontinue operation of the unit and contact qualified service personnel.

ROUTINE MAINTENANCE AND CARE

Routine Maintenance and Care

The Tucson requires minimal routine maintenance and care. The unit should always be cool and off when being cleaned.

WARNING: Do not substitute Materials.

For replacement parts, or for information about parts or service, contact your local HearthStone dealer.

Catalytic Combustor

The is the ceramic block with small square holes, located on top of the combustion chamber. **Do not attempt to clean the catalyst.** Attempts to clean the catalyst may be dangerous. The catalytic combustor does, however, require periodic visual checks. Inspect for damage, free flow, and buildup of contaminants. If any of these things are detected, replace the catalyst immediately. The catalyst should be replaced every 5 years (minimum).

Cleaning

The unit should receive regular cleaning on, under, and around the stove to prevent the buildup of dust and lint. The exterior surfaces of the unit can be cleaned using soap, water, and a soft cloth. Do not use abrasive or chemical cleaners and take care not to scratch the stones, glass, or enamel finish (if so equipped) when cleaning the unit. The use of chemical or wax based cleaners or polishes is not recommended due to the potential for discoloration of the stones when the residue of the cleaners or polishes is exposed to heat.

Firebox

The firebox should receive periodic cleaning to prevent the accumulation of dust, lint, and other debris. To clean the firebox, set the thermostat to the "OFF" position, and turn off the gas at the gas control

valve. When the unit is cool, unfasten the front door and carefully remove the decorative ceramic fiber log set (after they have cooled), taking care not to damage the logs or chip the enamel cast iron. Clean the firebox, burner tube, pilot assembly, and carefully vacuum the entire surface of the log set. Take care to thoroughly vacuum the ports (holes) along the top of the burner tubes and the pilot assembly.

Pilot & Burner Flames

With the decorative ceramic fiber logs out of the firebox, fasten the door shut and momentarily light the unit according to lighting instructions described in the How To Turn the Unit On & Off section of this manual. Check to ensure a flame is burning from each burner port. The pilot flame should be large enough to engulf the thermocouple as shown in *Figures 15a and 15b*. NOTE: Do not operate the unit for more than 1-2 minutes without the log set in place. Turn the unit off by setting the thermostat to "Off", and turning off the gas control valve. Allow the unit to cool.

ROUTINE MAINTENANCE AND CARE cont.

Check and clean any burner ports which were not burning properly or at all. Clean burner ports using a soft brush or vacuum cleaner. If the pilot flame height needs adjustment it should be adjusted by qualified service personnel as described in the Initial Adjustments section of this manual.

Complete the cleaning procedure by carefully placing the log set within the firebox as described in the Log Set Information section of this manual. Close and fasten the front door. Turn on the gas, light the unit and check for proper operation. Flame patterns should look like *Figure 14*. Regularly check to insure the area around the Tucson is kept free and clear from combustible materials, gasoline, and other flammable vapors and liquids. Check that the flow of combustion and ventilation air is not obstructed. **Once a year the unit should be inspected by qualified service personnel to ensure that it is clean, free of obstruction, safe, and in good working order. If service or maintenance is required, it should be performed by qualified service personnel.**

Replacing the Door Gasket

Your Tucson uses a 3/8" rope-type fiberglass gasket to make a tight seal between the door frame and the firebox. In time, the gasket can become brittle and compressed and should be replaced. New gasket material is available from your Authorized HearthStone Dealer.

Step 1. Allow the Tucson to cool completely.

Step 2. Open the door. Using a 1/8" allen wrench remove the door screw by turning counterclockwise.

Step 3. Remove the existing gasket by grasping one end and pulling firmly.

Step 4. Use a wire brush or the tip of a screwdriver to clean the channel of remaining gasket.

Step 5. Determine the correct length of the appropriate-sized gasket by laying it out in the channel. Allow an extra 1" to 2" (25-50 mm), and mark the spot to be cut.

Step 6. Cut the gasket at the marked spot with a utility knife. Twist the ends slightly to prevent the gasket from unraveling.

Step 7. Apply water glass adhesive to the gasket channel.

Step 8. Starting at one end, press the gasket into the channel. Ensure a good joint where the gasket ends meet before trimming any excess. Do not overlap the gasket ends or leave ends with ragged edges.

Step 9. Firmly and evenly press the gasket to seat it in its channel.

Cleaning the Glass

If operating on propane, it may be necessary to clean the inside of the glass occasionally. Do not use abrasive cleaners, steel wool, or a razor blade. Scratching the glass will weaken the integrity. Your dealer will usually stock a gas fireplace glass cleaner or a window cleaning fluid will work adequately. **Do not clean when hot!!**

WARNING: Do not operate this appliance with the glass panel removed, cracked or broken. Replacement of the panel should be done by a licensed or qualified service person. Contact your authorized dealer for replacement glass.

WARNING: Do not substitute Materials.

For replacement parts, or for information about parts or service, contact your local HearthStone dealer. For the name of the dealer nearest to you, phone or write:

HearthStone Quality Home Heating Products, Inc.
317 Stafford Avenue
Morrisville, Vermont 05661-8695
E-Mail: inquiry@hearthstonestoves.com

PARTS LIST

Part #	Description	Part #	Description
2710-115	bottom	5710-121	valve bracket support
2710-220	ash lip	5710-128	valve door
2710-321	right side	5710-131	ODS pilot bracket
2710-326	left side	5710-152	burner tube holder
2710-420	exhaust baffle	5710-160	log set holder
2710-486	heat exchanger	5710-470	stone clips
2710-511	front door	5710-511	firebox / air plenum
5710-170	door hinge with bracket	5710-515	exhaust baffle holder
5710-180	door latch bracket	5710-530	cat. heat shield
2710-560	glass ret frame	5710-597	back shroud
2710-581	front grill	7200-120	burner orifice #55
2710-810	top grill	7200-145	burner orifice #45
2710-818	top	7211-005	¾" Dia. gas line
2710-655	handle, door	7211-227	burner tube
1741-350	top side stones 3 5/16" x 10 5/16"	7211-301	gas valve sit (NG)
1741-351	side stones 7 1/2" x 6 1/2"	7211-305	gas valve sit (LP)
1741-352	top center stone 8 5/8" x 3 5/8"	7211-324	ODS pilot (NG)
7211-554	rear log	7211-327	ODS pilot (LP)
7211-555	middle log	7210-103	piezo igniter
7211-556	front log	3030-027	glass 13-3/16" x 11 1/4" x 5 mm
7211-557	top log	3010-157	catalyst combustion assembly
7211-558	charcoal ember (2 oz.)	3160-080	¾" tape (glass)
5320-070	ember screen	3110-057	¾" low density door rope
5710-119	light shield		
5710-120	back light shield		
7000-015	thermostat wire		
7200-506	thermostat		
7000-200	3-way on/off switch		

SPECIFICATIONS

Listed:

Vent-Free Gas-Fired Room Heater

Model:

Tucson Vent-Free Room Heater

Tested to:

ANSI Z21.11.2-1993, AGA 5-95

Testing Agency:

Intertek Testing Services NA Inc. (ITS)

Conditionally approved for purchased mobile home installation.

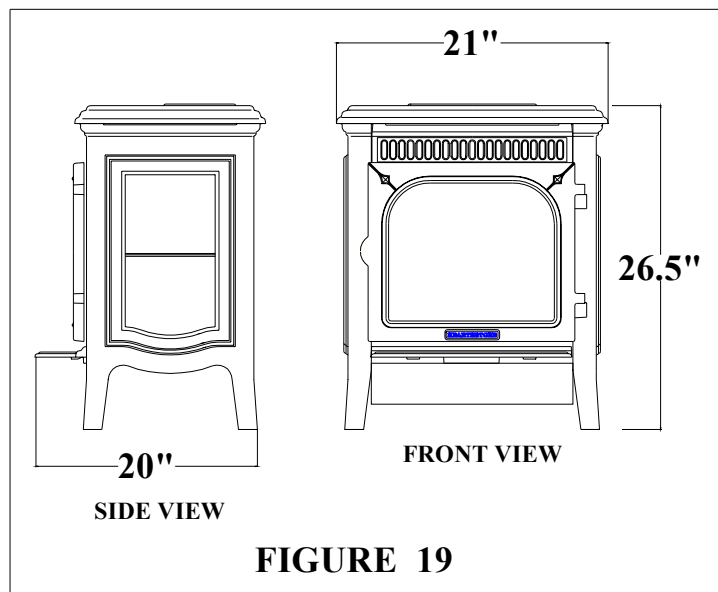

FIGURE 19

	Natural Gas	LP
Input rating (Btu/hr)	20,000	19,500
Maximum output (BTU/hr)	19,000	19,000
Minimum input rating (Btu/hr)	12,500	15,500
Orifice size DMS	45	55
Man. pressure-HI setting (in. w.c./kPa)	3.5/0.87	10.0/2.48
Man. Pressure-Lo setting (in.w.c./kPa)	1.6/0.42	6.4/1.59
Inlet pressure-HI (in. W.c./kPa)	10.5/2.6	14.0/3.47
Inlet pressure-LO (in. W.c./kPa)	5.0/1.24	11.0/2.88

TROUBLESHOOTING

Symptom	Possible Cause	Corrective Action;
1. Pilot will not light.	A. Insufficient gas pressure, air in the pilot line, or dirty or kinked gas line.	A. Using the piezo sparker, try to light the pilot. If it will not light, check the inlet gas pressure.
	B. Pilot orifice plugged. C. Defective or misaligned electrode at pilot. D. Defective ignitor. E. After sitting for "off" season (summer), pilot assembly may be dirty	B. Clean or replace the pilot assembly C. If a match lights the pilot, check the electrode gap and location. Should be a 1/8" gap in the flame area. D. Check for a good connection between ignitor and electrode. Check wire insulation. If properly connected and no spark, replace ignitor. E. Clean or replace the pilot assembly
2. Pilot will not stay lit after carefully following lighting instruction.	A. Low or too high gas pressure B. Faulty connections	A. Check for proper inlet pressure for the gas being used. B. Measure voltage between valve body and solder connection on the rear of the valve (where the blue wire connects). It should be no less than 7 mV.
	C. Defective thermocouple. D. Pilot dirty or plugged	C1. Ensure that the thermocouple connection at the gas valve is tight. C2. Check thermocouple output using milli-volt meter. Disconnect from valve and read voltage across wire ends. If the reading is less than 14 mV, replace the pilot assembly. C3. If burning NG, check pilot flame to see that it is impinging on the top 1/8" of the thermocouple. Clean or replace pilot for maximum flame impingement. D. Clean or replace the pilot assembly
3. Pilot burning, no gas to main burner, valve knob in the "ON" position ,On/Off/T-stat switch in the "ON" position, or if "T-stat" is selected, Thermostat is in the "ON" position .	A. If "T-stat" is selected, thermostat switch or wires defective.	A. Check thermostat/wiring for proper connections. Place Jumper wire across terminals at thermostat. If burner comes on, replace defective thermostat. If not OK, place jumper across thermostat wires at gas valve. If burner comes on, tighten connections, or replace faulty wires.
	B. Thermopile may not be generating sufficient voltage. C. Plugged burner orifice.	B. Check thermopile output, using a milli-volt meter. If the optional on/off kit has not been installed, take the readings across generator terminals of the gas valve. (TPTH and TP). With the on/off kit, take the readings across TH and Terminal block(which corresponds to #3 on the switch). Millivolt reading should be greater than 325 mV. If not, replace the pilot assembly. If the meter reading is OK, but the burner does not come on, replace the gas valve. C. Remove and check burner orifice, clean or replace. Note: do not use any metal cleaning device, as this may damage the orifice.
4. Pilot and burner come on, but go out after some warm-up.	A. Inconsistent, of insufficient flame on thermopile.	A. Adjust flame size and assure that the flame is aimed directly at the thermopile.
	B. Insufficient gas pressure.	B. Check line pressure to ensure that the correct inlet pressure is present for the type of gas being used. If propane pressure is inconsistent, check for water condensation at the regulator.

TROUBLESHOOTING cont.

Symptom	Possible Cause	Corrective Action
5. Frequent pilot outage problem.	A. Pilot may be too low or blowing, (high), causing the pilot safety to drop out.	A. Clean and/or adjust the pilot flame for maximum impingement on the thermopile and thermocouple.
6. Glass fogs	A. A normal result of gas combustion.	A. After the heater has warmed up, the glass should clear.
7. Blue Flames	A. A normal result during the first 20 minutes.	A. Flames should begin to turn more yellowish after 20 minutes of burning.
8. Floating flames, lazy ill-defined, quiet flames which roll around, sometimes completely off of the port, sometimes with overly yellow tips). Possible sooting. Usually accompanied by the odor of aldehydes.	<p>A. Potentially dangerous incomplete combustion due to incorrect air to fuel ratio (lack of combustion air or excessive fuel delivery i.e. excessive gas pressure, overrating of appliance).</p> <p>B. Incorrect air intake/exhaust flow system. Causes may be:</p> <p>B1. Blocked burner</p> <p>B2. Blocked primary air</p> <p>B3. Blocked secondary air inlets</p> <p>B4. Plugged catalytic combustor</p>	<p>A. Check the appliance input rate and reduce if necessary. The air intake/exhaust flow system may be too restrictive or blocked (the rate at which the exhaust leaves [draft] determines the rate at which the combustion air is delivered). Poor draft results in insufficient air delivery or a restricted exhaust. Correct air intake/exhaust flow system.</p> <p>B1. Clear ports</p> <p>B2. Clear obstructions</p> <p>B3. Clear obstructions.</p> <p>B4. Replace catalytic combustor</p>
9. Burner Flashback. Air-gas mixture ignites inside the burner near the orifice, usually creating a roaring noise like a blow torch. The problem is an imbalance of gas flow velocity and burning speed pattern.	<p>A. Excessive.</p> <p>B. Burner input underrated.</p> <p>C. Valve leak if flashback occurs with burner valve in off position</p> <p>D. Improper gas pipe size</p>	<p>A. Set primary air to factory setting.</p> <p>B. Check input rate. Check input pressure using a manometer. Confirm correct gas pressure at house meter or tank (call gas company). Confirm burner orifice size.</p> <p>C. Replace valve. If above corrections do not eliminate flashback, replace burner.</p> <p>D. Correct plumbing</p>
10. Delayed ignition (makes a sudden "whoosh" noise as the burner lights). This is a buildup of gas's prior to ignition. This is more prevalent with propane (LP) fuel.	<p>A. Incorrect air-to-fuel ratio.</p> <p>A1. Primary air incorrect</p> <p>A2. Burner ports plugged</p> <p>B. Pilot not positioned properly</p> <p>C. Improper log placement</p>	<p>A1. Set primary air to factory setting</p> <p>A2. Open ports to allow for proper travel of flames.</p> <p>B. Adjust pilot location so it is close enough to light ports on burner tube.</p> <p>C. Reposition logs to eliminate interference with flame travel</p>

HEARTHSTONE GAS-FIRED STOVE AND INSERT LIMITED WARRANTIES

These warranties give you specific legal rights. You may also have other rights which vary from State to State.

HearthStone Quality Home Heating Products, Inc. (HearthStone) warrants **to the original purchaser only** (the "Original Purchaser") the new gas-fired stove/insert manufactured by HearthStone and purchased by the Original Purchaser (referred to as the "Stove" for simplicity) against any of the occurrences listed in this document that result from defects in material or workmanship. All obligations of HearthStone under this document commence on the date the Original Purchaser purchases the Stove (the "Purchase Date").

LIMITED LIFETIME WARRANTY

HearthStone warrants the following parts of the Stove against the following occurrences that result from defects in material and workmanship:

- All cast iron parts, including the cast iron heat exchanger – against breakage, cracking or burn-through.
- All stones – against cracking or breakage due to thermal stress, **excluding** surface and hairline cracks and scratches that do not affect the operation or safety of the Stove.
- Glass – against breakage due to thermal shock.

LIMITED FIVE-YEAR WARRANTY

HearthStone warrants the following parts of the Stove against the following occurrences that result from defects in material and workmanship:

- Firebox and firebox baffle – against breakage, cracking or burn-through.
- Convective heat exchanger – against breakage, cracking or burn-through.
- Burners, air shutters and orifices – against breakage, cracking or burn-through.
- Ceramic logs and embers – against breakage, cracking or burn-through.

This warranty expires on the fifth (5th) anniversary of the Purchase Date.

LIMITED THREE-YEAR WARRANTY

HearthStone warrants the following parts of the Stove against the following occurrences that result from defects in material and workmanship:

- Gas train, including gas valve, millivolt wiring, spill switch, pilot assembly, thermopile, thermocouple, piezo igniter, and, if the Stove is a vent-free model, ODS system – against breakage or malfunction.

This warranty expires on the third (3rd) anniversary of the Purchase Date.

LIMITED ONE-YEAR WARRANTY

HearthStone warrants the following parts of the Stove against the following occurrences that result from defects in material and workmanship:

- Enamel Finish – against peeling or fading, **excluding** chipping, mechanical abrasion, chemical abrasion or crazing.

- Gaskets and sealants – against breakage or deterioration.

- Accessories and electrical components such as blowers, switches and thermo discs, **excluding** venting components, hearth components, electrical components and other components or accessories used in conjunction with the installation of the Stove ***not*** manufactured or supplied by HearthStone – against breakage or malfunction.

This warranty expires on the first (1st) anniversary of the Purchase Date.

EXCLUSIONS

The warranties contained in this document do not cover, nor is HearthStone responsible for:

- Damage resulting from installation or operation of the Stove in a manner contrary to the owner's manual.
- Damage or non-performance resulting from faulty or incomplete setup, installation and start-up or

- mishandling, abuse, or misuse of the Stove, including but not limited to over-firing.
- Damage resulting from installation, modification, alteration, repair or service of the Stove by any party other than HearthStone or an authorized HearthStone dealer (a "Dealer").
- Damage due to water or due to installation of the Stove in a damp or high condensation area.
- Damage due to installation of the Stove in an atmosphere contaminated by damaging chemicals, including but not limited to chlorine, fluorine or salts.
- Scratches on glass, enameled surfaces or stones due to mechanical abrasion.
- Standard wear and tear of the Stove resulting from normal usage over time.
- Damage, operational-related problems, or inadequate performance caused by site, installation or environmental conditions beyond HearthStone's control, including but not limited to nearby trees, rooftops, buildings, wind, hills, mountains, inadequate or excessive venting, insufficient make up air, or negative air pressure whether or not caused by mechanical systems such as furnaces, exhaust fans, clothes dryers, etc.
- A defect in any part of the Stove if the Original Purchaser fails to comply with HearthStone's or a Dealer's request to ship the part or the Stove to HearthStone or a Dealer, as the case may be.

THE WARRANTIES CONTAINED IN THIS DOCUMENT ARE EXCLUSIVE AND ARE GIVEN BY HEARTHSTONE AND ACCEPTED BY THE ORIGINAL PURCHASER IN LIEU OF ALL OTHER EXPRESS WARRANTIES AND ANY OBLIGATIONS, LIABILITIES, RIGHTS, CLAIMS, OR REMEDIES IN CONTRACT OR TORT, WHETHER OR NOT ARISING FROM HEARTHSTONE'S NEGLIGENCE, ACTUAL OR IMPUTED. ALL IMPLIED WARRANTIES, INCLUDING THE WARRANTIES OF MERCHANTABILITY AND FITNESS FOR A PARTICULAR PURPOSE, ARE GIVEN **ONLY** TO THE EXTENT REQUIRED BY FEDERAL OR STATE LAW. EXCEPT AS OTHERWISE REQUIRED BY STATE LAW, UPON THE EXPIRATION OF THE EXPRESS LIMITED WARRANTIES CONTAINED HEREIN, **NO** IMPLIED WARRANTIES, INCLUDING THE IMPLIED WARRANTIES OF MERCHANTABILITY OR FITNESS FOR A PARTICULAR PURPOSE, SHALL APPLY TO THE SUBJECT STOVE. **SOME STATES DO NOT ALLOW LIMITATIONS ON HOW LONG AN IMPLIED WARRANTY LASTS, SO THE ABOVE LIMITATION MAY NOT APPLY TO YOU.**

THE WARRANTIES CONTAINED IN THIS DOCUMENT EXTEND **ONLY** TO THE ORIGINAL PURCHASER OF THE STOVE WARRANTED HEREUNDER. THEY DO NOT EXTEND TO ANY SUBSEQUENT OWNERS.

UNDER NO CIRCUMSTANCES SHALL HEARTHSTONE BE LIABLE TO THE ORIGINAL PURCHASER OR ANY OTHER PERSON FOR ANY INCIDENTAL OR CONSEQUENTIAL DAMAGES, INCLUDING BUT NOT LIMITED TO DAMAGE TO PROPERTY OR PERSONAL INJURIES, WHETHER ARISING OUT OF BREACH OF WARRANTY, TORT, OR OTHERWISE, EVEN IF HEARTHSTONE HAS BEEN APPRAISED OF THE POSSIBILITY OF SUCH DAMAGES. **SOME STATES DO NOT ALLOW THE EXCLUSION OR LIMITATION OF INCIDENTAL OR CONSEQUENTIAL DAMAGES, SO THE ABOVE LIMITATION OR EXCLUSION MAY NOT APPLY TO YOU.**

QUALIFYING FOR WARRANTY COVERAGE

To obtain performance of any obligation under this document, the Original Purchaser must, **within the applicable warranty time period**, contact HearthStone, at the address listed in the Warranty Registration section below or at **(802) 888-5232**, or a Dealer for instructions regarding the return of defective parts for repair, the return of the stove for repair, or a Dealer service call. The Original Purchaser should refer to the Dealer network search engine contained on HearthStone's Web site (www.hearthstonestoves.com), or call HearthStone at (802) 888-5235, to find a Dealer nearest the Original Purchaser's location.

REMEDY

The remedy for any breach of the foregoing warranties will consist of repair or replacement, at HearthStone's option, of any covered defect in the Stove. When the Original Purchaser contacts HearthStone or a Dealer, HearthStone or the Dealer, as the case may be, will instruct the Original Purchaser to **either** return the defective

part, or the entire Stove (if needed), with shipping prepaid, to HearthStone or a Dealer **or** allow a Dealer to make a service call at the place where the Stove is located. In the event the Original Purchaser refuses to allow a Dealer to make a service call, HearthStone or a Dealer, as the case may be, will request that the Original Owner return the defective part, or the entire Stove (if needed), with shipping prepaid, to HearthStone or a Dealer. **Notwithstanding any other provision of this document, the Original Purchaser shall pay for any travel fees and service charges related to a Dealer's service call.**

Parts: HearthStone will replace defective parts covered by the foregoing warranties at no charge.

Labor: Within the first (1st) year after the Purchase Date, HearthStone will pay for warranty labor performed by a Dealer at HearthStone's published labor rates in effect at the time the labor is performed. Thereafter, the Original Purchaser is responsible for the cost of labor.

Shipping cost for parts: Within the first ninety (90) days after the Purchase Date, HearthStone will pay for the shipping of Stove parts covered by any of the foregoing warranties to and from HearthStone or a Dealer, as the case may be. Thereafter, the Original Purchaser is responsible for all shipping costs related to shipping Stove parts to and from HearthStone or a Dealer, as the case may be.

Shipping cost for the Stove: Within the first (1st) year after the Purchase Date, if the Original Purchaser is instructed to return the Stove to HearthStone or a Dealer for repair, HearthStone will pay fifty percent (50%) and the Original Purchaser will pay fifty percent (50%) of the shipping costs related to shipping the Stove to and from HearthStone or a Dealer, as the case may be. Thereafter, the Original Purchaser is responsible for one hundred percent (100%) of all of the shipping costs related to shipping the Stove to and from HearthStone or a Dealer, as the case may be. Notwithstanding any other provision of this document, in no event will HearthStone pay for any Dealer fees or other fees for pick up or delivery of the Stove returned for repair; the Original Purchaser shall be responsible for any such fees.

WARRANTY REGISTRATION

The Original Purchaser may send a completed and signed Warranty Registration Form, which is enclosed in the Stove warranty packet, to the following address:

**HearthStone Quality Home Heating Products, Inc.
Warranty Department
317 Stafford Avenue
Morrisville, VT 05661-8695**

NOTE: SENDING IN THE SIGNED WARRANTY REGISTRATION FORM IS *NOT* A CONDITION OF WARRANTY COVERAGE OR HEARTHSTONE'S PERFORMANCE.