



Technical Data Sheet

Craftsbury Model 8390 Front Door Latch Coil Spring Upgrade *Kit #93-73900*

Publish Date: 12/14/2006

MATERIALS INCLUDED:

Latch (5390-050)
Crank (5010-081)
Spring (5240-137)
Washer (5021-032)
Setscrew (4500-2975)
Spacer (4700-0790), 4ea

TOOLS REQUIRED:

5/32" Hex wrench
Slotted Screwdriver

PROCEDURE:

- 1) Remove the old door latch assembly by loosening the setscrew located in the chrome crank with the hex wrench. When loosened, unscrew the outer and inner portions of the latch, separate, and removed from the stove. Remove the bolt and wooden handle (if connected) and save these for installation on the new latch assembly. Discard all other original latch pieces.
- 2) Install the new latch assembly as shown in the illustration. Begin with two shim spacers placed on the shaft of the latch. Push the threaded end of the latch shaft through the door so the threads are on the outside of the door.
- 3) Place the large washer over the threaded portion of the latch shaft and then slide the coil spring over the shaft of the latch so that it rests on top of the washer. Thread the chrome crank onto the latch and over the coil spring. Turn the crank until there is approximately 1/8" between the crank and the washer.
- 4) Align the setscrew hole in the crank with the flat surface on the latch shaft. Insert and tighten the setscrew. Turn the latch slightly back and forth while tightening to seat the setscrew.
- 5) Install the bolt and wood handle removed in step one.
- 6) Check door seals using the "dollar bill test." Shut the door on a dollar bill. If the bill pulls out without any resistance, then your stove's door isn't sealed properly. Remove or add spacers to the inside of the latch to adjust gasket pressure. Remove a spacer to draw the door in tighter.

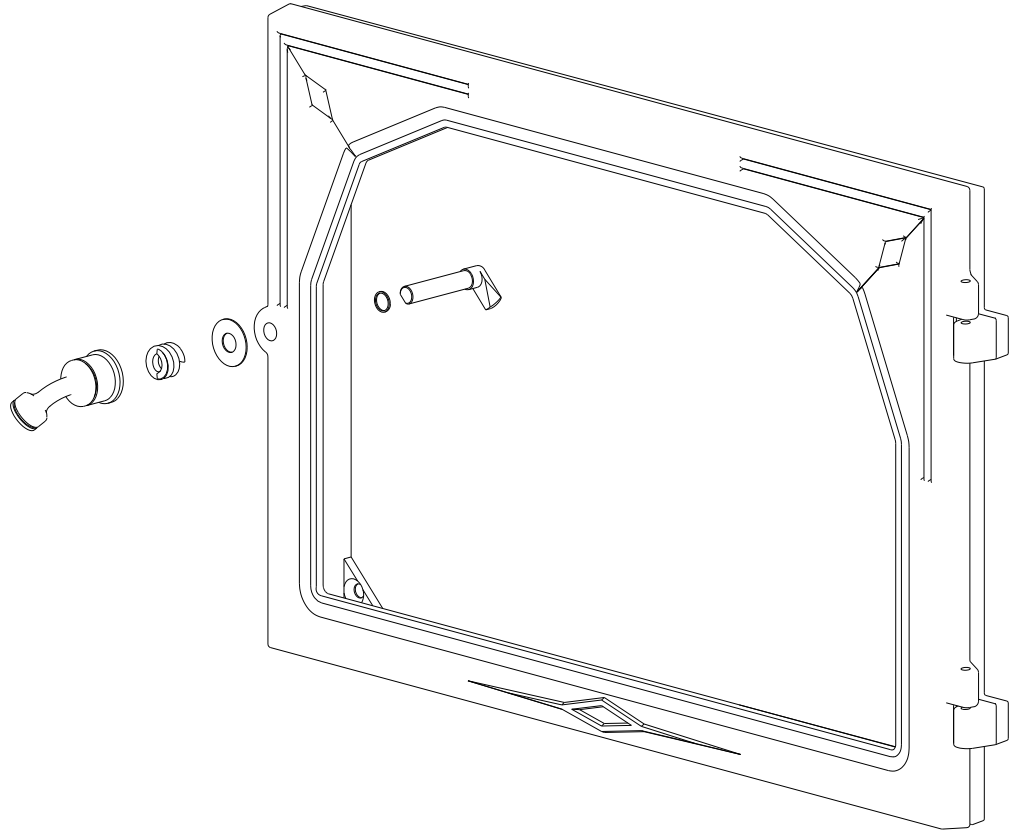

Figure 1
Exploded view of latch components