

Technical Data Sheet

Manchester 8360, 8361 Replacement Glass Kit *Assembly 93-58300*

KIT CONTENTS:

<u>Quantity</u>	<u>Part Name</u>	<u>Part Number</u>
1	Replacement Ceramic Glass	3030-059
6 feet	1/4" Self-adhesive Rope Gasket	3110-056
8	Glass retaining clips	3120-021
8	Glass clip gaskets (fiber pads)	5021-060
8	10-24 3/8" pan head Phillips screws	4500-2105

TOOLS REQUIRED:

#2 Phillips Screwdriver
3/8" Wrench
7/16" Wrench
Pr. Work Gloves
Penetrating Oil

BEFORE YOU BEGIN: *Install on a cool stove only!!*

The replacement ceramic glass has an infrared coating on one side. It will be identified with either a small white label, or the word "coated" on the coated side. Be sure that this side of the ceramic glass sheet goes toward the outside of the stove after installation and with the door closed (away from the firebox). Also, if the existing glass insert is broken use caution around all sharp edges.

PROCEDURE:

1. Prepare a smooth and sturdy work surface large enough to accommodate the front door of your stove. Cover the surface in cardboard or soft fabric to prevent damage to your door finish during this procedure.
2. Remove the two 10-24 acorn nuts and washers attaching the top casting to the body of the stove using the 3/8" wrench (see Figure 1 for mounting hardware locations and terminology).
3. Place two 10" pieces of 2"x4" wood or thick cardboard strips on a diagonal between the top casting and the top of the stove body at the back two corners (Figure 1). This is to prevent chipping on enamel stoves.
4. Gently lift the leading (front) edge of the top casting and prop it up from the firebox with an additional 10" piece of 2"x4". Be careful to position this prop in the center of the top casting leading edge and on the flat portion of the firebox top. Do not prop on firebox heat fins. The top casting should now be at an angle front high with the back edge resting on the stove body (separated by spacing material installed in step 1).

5. Look along the front edge of the now exposed firebox for the two Front Grill mounting studs. They will be located at the far right and left edges of the grill and will hold it to the body of the stove by sliding into two prominent cast slots on the firebox and fastening with a 1/4" nut and washer. Using the 7/16" wrench, loosen these two nuts. It is not necessary to remove them entirely.
6. Gently lift the Front Grill from the body of the stove and set it aside being careful not to damage the finish.
7. Open the front door to about 3/4 of full travel.
8. Stand facing the front side of the door with your right hand close to the hinge side and your left to the front door latch side. With an underhanded grip on your right hand, firmly grab the door face bottom rail. Grip the door face rail on the latch side with your left hand and gently but firmly raise the door straight vertically up until it is free from the hinge pivots. Once the door is free from the hinges it may move suddenly. Take care not to allow the door to contact the stove and potentially damage the finish.
9. Place the door face down on the prepared work surface.
10. With the door in this position, apply penetrating oil to each of the glass retention screws.
11. Using the #2 Phillips screwdriver, remove the 8 screws that hold the retaining clips to the inside of the door.
12. Remove the loose clips and fiber pads.
13. Carefully remove the old glass and gasket and discard. **CAUTION:** If the glass is broken, remove the glass with work gloves. Make certain all glass debris is cleaned from the door.
14. Locate the end of the existing Front Door Glass Gasket. This should be situated between the hinge pivots on the hinge side of the door.
15. Grip one end of the existing rope gasket and gently pull the entire unit from the door frame. Discard the used gasket material.
16. Thoroughly clean the gasket channel using steel wool or a small wire brush. Wipe the channel clean with damp rag or cloth.
17. Peel the paper backing from a short section of the 1/4" self-adhesive rope gasket. Beginning at a position centered between the two hinge pivot projections, gently press the adhesive side of the rope gasket into the recessed gasket channel until it adheres to the floor of the groove (see Figure 3 for starting position). Continue peeling back the paper backing and pressing the new gasket adhesive side down into the gasket channel around the entire perimeter of the glass opening. Be careful not to stretch the gasket material during this process. When you have returned to your starting point, cut the rope gasket at such a location that the ends meet with no gap. Discard any extra gasket.
18. Set the new ceramic glass panel onto the door with the white label facing the outside of the door (refer to the Before You Begin section of this document). Center the glass on the opening.

19. Position the 8 new fiber pads on the glass panel parallel to the glass edge at each retention clip mounting screw location.
20. Position the 8 new retention clips over each fiber pad as shown in Figure 2.
21. Insert the 8 new screws through the glass retention clips and lightly snug the screws in a clockwise pattern around the perimeter of the door.
22. Once all screws are in place, fully tighten them again in a clockwise pattern making sure the fiber pads stay centered under the clips.
23. Return the door to the stove and gently slide the door hinges back over the hinge pins
24. Carefully slide the Front Grill studs back into the mounting slots, assure the washers are on the back side of the slot tabs (touching the nuts), and re-snug the retaining nuts.
25. Remove the prop device installed in step 4 above and gently lay the leading edge of the top casting back down on the top of the stove body.
26. Remove the wood or cardboard inserted in step 3 above and gently return the top casting to its original position on the stove body.
27. Reinstall and tighten the washers and acorn nuts removed in step 2 above.

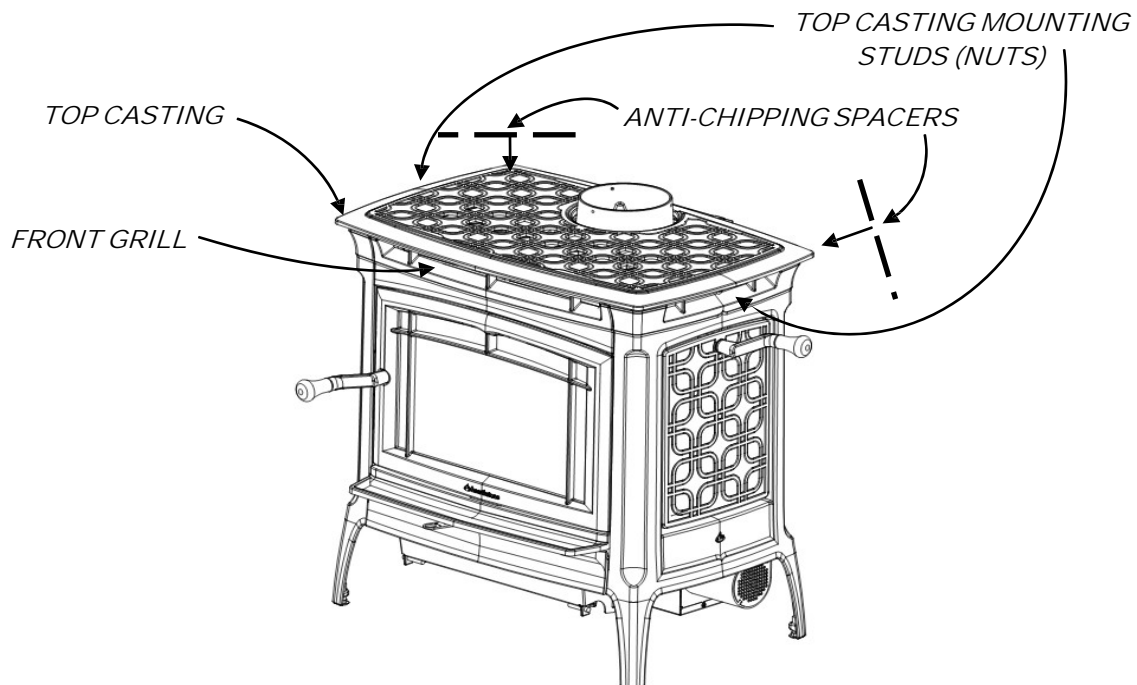

MANCHESTER TERMINOLOGY

Figure 1

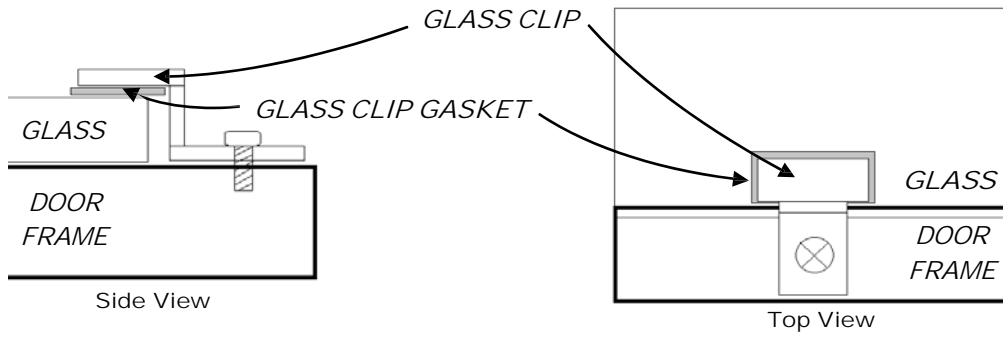

GLASS CLIP/GASKET ORIENTATION

Figure 2

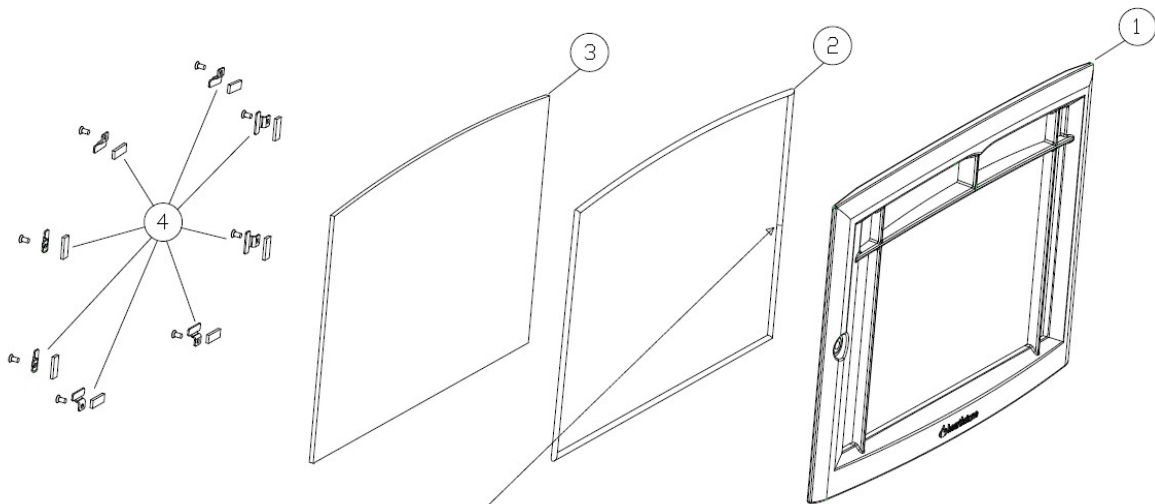

Note:
 Position glass gasket material in such a manner that the break is centered vertically on the hinge side of the door.

- ① 2310-610 Front Door
- ② 3110-056 1/4" self-adhesive non-core gasket
- ③ 3030-059 Ceramic Glass Panel
- ④ 3120-021 Glass Clips/Gaskets

MANCHESTER GLASS KIT

Figure 3