



Technical Data Sheet

Tucson 8701 & Stowe 8321 Conversion From LP To NG

Assembly #93-56210

Date: April 1, 2004

Page: 1 of 4

93-56210 – KIT COMPONENTS:

7211-312 - NG Valve Regulator
7200-340 - #40 Burner Orifice
7211-163 – .62mm Pilot Orifice
NG Sticker (White)
Instructions – 4 Pages

TOOLS REQUIRED:

Phillips Screwdriver
Slotted Screwdriver
Straight Handled T20 Torx
½” Deep Socket
5-32” Allen Wrench
3” Socket Extension

!!WARNING!!

This conversion kit must be installed by a qualified gas service agency in accordance with the manufacturer’s instructions and all applicable codes and requirements of the authority having jurisdiction. If the information in these instructions is not followed exactly, a fire, explosion, or production of carbon monoxide may result causing property damage, personal injury, or loss of life. The qualified service agency performing this work assumes responsibility for the proper conversion of this appliance with this kit.

WARNING!!

This conversion kit must be installed by a qualified gas service agency in accordance with the manufacturer’s instructions and all applicable codes and requirements of the authority having jurisdiction. If the information in these instructions is not followed exactly, a fire, explosion, or production of carbon monoxide may result causing property damage, personal injury, or loss of life. The qualified service agency performing this work assumes responsibility for the proper conversion of this appliance with this kit.

!!ATTENTION!!

Cet équipement de conversion sera installé par une agence qualifiée de service conformément aux instructions du fabricant et toutes exigences et codes applicables de l’autorisés avoir la juridiction. Si l’information dans cette Instruction n’est pas suivie exactement, un feu, explosion ou production de protoxyde de carbone peut résulter le dommages causer de propriété, perte ou blessure personnelle de vie. L’agence qualifiée de service est esponsable de l’installation propre de cet équipement. L’installation n’est pas propre et complète jusqu’à opération de l’appareil converti est chèque suivant les critères établis dans les instructions de propriétaire provisionnées avec l’équipement.



CAUTION: The gas supply must be shut off before making this conversion. If the stove is equipped with the optional blower, disconnect it from the electrical source before making this conversion.

IMPORTANT: These instructions are for the Direct Vent stoves listed on the cover page only – DO NOT attempt this conversion on a Vent Free Tucson.

PROCEDURE:

- 1) Open the front of the stove. For the Tucson use the 1/8" allen wrench provided with the stove to remove the screw that holds the front door closed. For the Stowe, remove the two phillips screws on the top of the front panel that are used to hold the face of the stove in place during transportation. Once the screws are out, drop the ash lip down and locate the lever to release the easy off front. Carefully hold the front at the top, pull the lever up to release it. Now you can remove the front panel and place it in a safe place until it is required for reassembly.
- 2) Remove the stainless steel pan burner from the firebox. To remove the burner in the Tucson or Stowe, you must first remove the retaining screw located in the back of the burner assembly.
- 3) Locate the main burner orifice that is located inside the air shutter box in the rear center of the firebox (see photo on page 4). Insert a 1/2" deep socket with a 3" extension into the round opening in the front of the air shutter box to remove the LP gas orifice. Install the #40 NG orifice provided with this kit and snug with the socket and extension. **NOTE:** Stoves installed above 2,000 feet (610m) in Canada may require a derated orifice (see specifications page 4).
- 4) Locate the pilot assembly inside the stove that has also been exposed by removal of the pan burner system (see photo page 4). Remove the easy off top of the pilot burner hood by grasping it and pulling it up and off the pilot assembly.
- 5) Using a 5/32" allen wrench, unscrew and remove the LP pilot orifice. Insert the 62mm ng orifice provided with this kit and tighten it with the allen wrench.
- 6) Snap the pilot burner hood back into place on the pilot stem, making sure the cutout of the hood aligns with tang on the orifice housing.
- 7) Adjust the air shutter by turning the bolt on the outside back of the stove. Turn the bolt out, away from the stove one to three full revolutions to open the air shutter. After the conversion is completed, adjustments in the flame can be made from outside the stove. **Important:** Make certain that orange flames are not present as this is a sign of incomplete combustion and will produce soot.
- 8) Insert the burner system back into the firebox. Secure the burner with the phillips screw previously removed in step two. Refer to the owner's manual for the proper placement of the logs and embers. Replace and secure the front door (Tucson) or Glass front (Stowe). It will not be necessary to replace the top bolts on the face of the Stowe that were removed in step one.

VALVE CONVERSION: See illustrations below.

- 9) Using a Torx T20, or slotted screwdriver, remove and discard the three pressure regulator mounting screws (A), pressure regulator tower (B) and diaphragm (C).
- 10) Insure that the rubber gasket (D) is properly positioned and install the new HI/LO pressure regulator assembly to the valve using the new screws (E) supplied with the kit. Tighten screws securely.
- 11) Install the enclosed identification label (F) to the valve body where it can be easily seen. Place the White NG sticker over the Red LP sticker on the valve door.
- 12) Turn on the gas supply. For checking and properly adjusting the manifold pressure, refer to the appliance owner's manual for instructions.

LEAK TEST ALL FITTINGS BEFORE AND AFTER LIGHTING THE STOVE WITH A GAS SNIFFER.

The input rate of the heater can be verified by checking the manifold pressure. If the manifold pressure is correct, then the input rate is correct.

- 13) Record this change by filling out the fuel conversion label on the back of the stove.

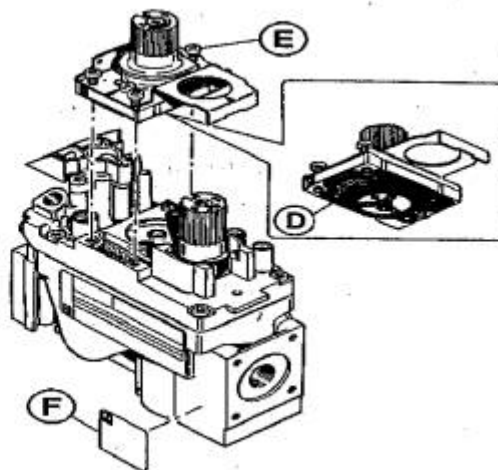
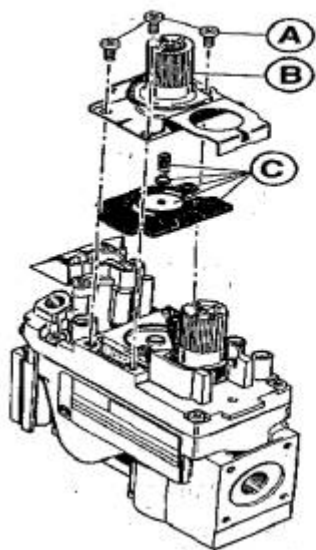



Photo shows Pilot assembly (left) and air shutter with burner orifice (right) in the firebox after the pan burner has been removed.

	<u>Natural Gas</u>	<u>LP</u>
Input rating (Btu/hr) 0 - 2,000	26,000	26,000
Maximum output (BTU/hr) 0-2,000 ft	18,100	18,100
Minimum input rating (Btu/hr)	15,600	15,600
Orifice size DMS 0- 2,000 ft	40	53
Input rating (Btu/hr) 2,000 to 4,500 ft	25,500	25,000
Orifice size DMS 2,000 – 4,500 ft	41	54
Manifold pressure-Hi Setting (in. w.c./kPa)	3.5/0.87	10.0/2.48
Man. Pressure-Lo setting (in.w.c./kPa)	1.2/0.3	3.3/0.8

Note: Refer to the owner's manual for the:

- Details on adjustment for the proper pilot and main burner flame appearance.
- Instructions for checking out the normal operating sequence of the ignition system.
- Location on the valve to check manifold pressure.

DO NOT REUSE THE PARTS THAT WERE REMOVED FROM THE STOVE